

# TS37



The TS37 side seal horizontal shrink wrapper is one of the most versatile packaging machines on the market today. Capable of wrapping up to 80 packages per minute, the continuous motion TS37 film folding system eliminates the need for multiple forming heads with its adjustable film former.

Unlike conventional film inverters, the TS37 film path ensures equal transfer of grouped products onto the film without skewing the product configuration. This is ideal for multipacks and irregular shaped products. The machine features an electronically adjustable pouch length, which enables “on-the-fly” bag length changes without changing the flight spacing. All adjustments are made with a user-friendly color touchscreen where product changeovers can be completed quickly and easily - without tools.

The TS37 uses single wound film which is less costly than centerfolded. A unique side sealing mechanism ensures strong attractive trim seals using polyolefin, PVC or polyethylene shrink film. The TS37's cross-seal system uses a hot knife seal and cut-off, with a precision temperature control that maintains accurate heat settings. An independently driven scrap removal system compacts excess film.

A sliding film rack allows easy roll loading and reduces film changeover time. Located beneath the film forming table, the film rack requires no additional floor space.

Compact in design, the TS37 is easily integrated into any existing production environment.



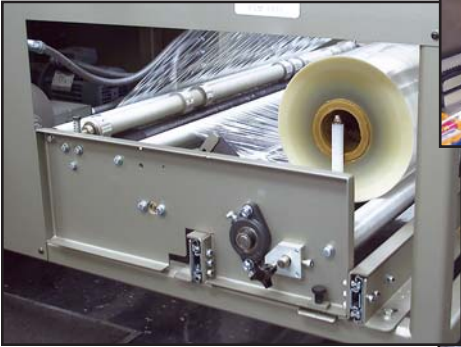

Slide Out Film Rack with Needle Hole Punch System



Horizontal Sealing System



Vertical Sealing System

## APPLICATIONS

The TS37's unique side seal process keeps package graphics distortion-free with neatly formed trim seals created extremely close to the product. The TS37 is perfect for artwork, mailers, compact discs and low-profile stacks of paper products such as napkins and greeting cards. This flexible system is also ideal for tall products such as bottles when utilizing the vertical sealing system, and optional film support former.

- Bottles
- Mailers
- Cosmetics
- Games
- Spray cans
- Paper products
- Food products
- Pharmaceutical
- Multipacks
- Linens
- Toys
- Hardware
- Software



TS37 Wrapping Pizza Dough



TS37 Wrapping Dry Ice



TS37 Wrapping Squash



User-Friendly Operator Controls

## FEATURES

- Heavy-duty rugged construction for high durability and around-the-clock operation
- Laser cut and CNC machined components for maximum precision and strength
- Powder coat finish that provides a durable scratch resistant surface and prevents corrosion
- Horizontal / vertical cross seal
- Allen-Bradley® programmable logic controller
- ARPAC's operator interface with color touchscreen, message display and self-diagnostics
- Guards and control box doors are electrically interlocked
- 6' flighted infeed with safety torque limiter
- Adjustable film forming head
- Continuous motion seal head for smooth product transitions
- 8" seal bar opening
- Slide out film rack with needle wheel air evacuation assembly
- Missing product detection
- NEMA 12 main electrical cabinet and controls
- Rapid hand wheel changeover
- Evenly wound trim removal system compacts film trim for easy disposal
- Relaxed film tension at cross seal
- Central point lubrication simplifies preventive maintenance
- Low film alert warns that a film changeover will soon be necessary

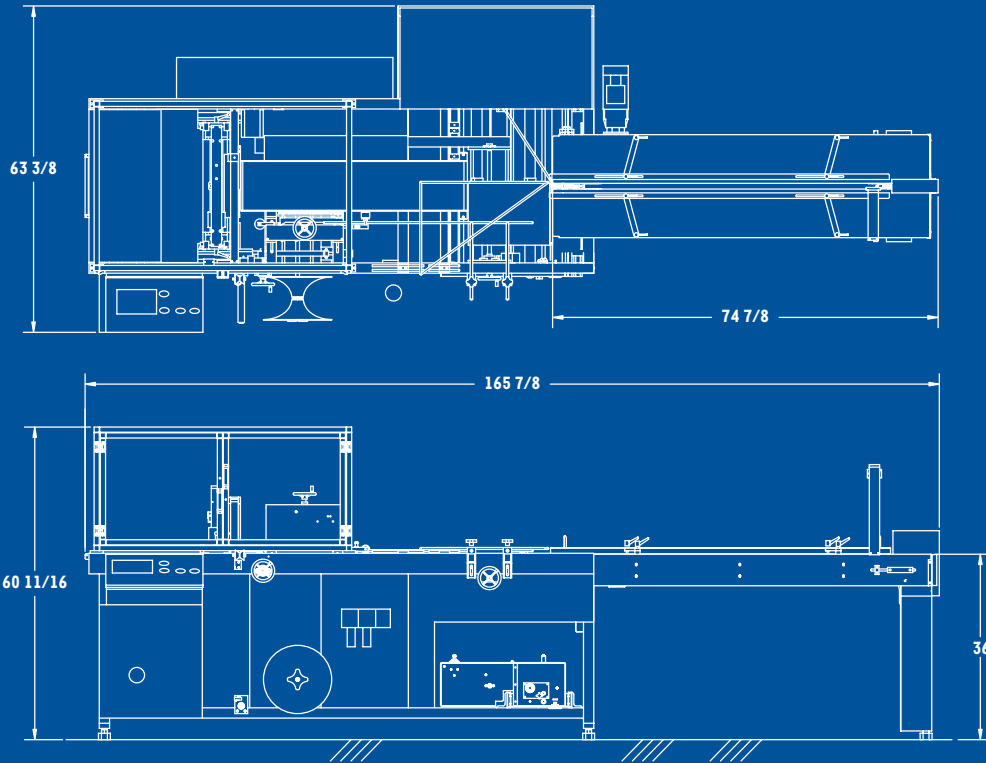

## SPECIFICATIONS

### Speed

- Output speed: up to 80 packages per minute (based on product specs)
- Output speed: up to 90 linear feet per minute

### Power Requirements

- Electrical: 230V, 1Ph, 22A
- Pneumatic: 80 psi, 5 SCFM

### Product Range

Product Size	Width	Length	Height
Seal Bar (Vertical)	2" - 7.5"	3 1/2" - 60"	2" - 12"
Seal Bar (Horizontal)	2" - 16"	3 1/2" - 60"	1/4" - 7.5"

Specifications and product sizes may vary, depending upon the application.

Max. package dimensions cannot occur together.

### Film

- Max. film width: 39" single-wound
- Max. film roll diameter: 14"

## OPTIONS

- Belted infeed
- Seal jaw bridge
- Extended flighted infeed
- Random & infinite length infeeds
- Stainless steel construction
- Low pressure roller infeed with automatic speed zone control
- Application specific infeeds
- Print registered film capability
- Pneumatic hole punch system
- Easy open film perforation system
- 460V, 3Ph, 15A

