

CAPRA® 8000SS



PACKAGING SOLUTIONS THAT MEAN BUSINESS

CAPRA® 8000SS

HIGH-SPEED SIDE SEAL HORIZONTAL SHRINK WRAPPER

CAPRA® 8000SS



"Quick-Connect" infeed conveyor shown with optional hoppers

ARPAC's CAPRA® 8000SS side seal horizontal shrink wrapper ensures maximum performance at speeds up to 140 packages per minute or 140 linear feet of film per minute.

Ideal for full film over-wrapped packages for retail display, the CAPRA® 8000SS shrink wraps small and large product sizes, from pharmaceuticals to construction materials. This flexible shrink wrapper has a 24" wide seal bar and a 10" high seal bar opening that can be configured to run vertical end seals for tall packages.

Tool-less changeovers are fast and few with ARPAC's film forming and delivery system. A proven "no contact" side seal runs polyethylene, polyolefin, PVC and PLA films without changeover, with no build-up of film on the seal mechanism. This machine runs single-wound shrink film, which is less costly than center-folded film and runs twice as long.

Fast and easy film threading gets you back up and running in minutes. The operator-friendly ergonomic design conveniently locates all operator controls, film loading, and changeover functions on the same side of the machine.

A unique film folding mechanism uses narrower film for maximum return on investment. Flat film is fed up from a roll beneath the film inverter. Unlike conventional film inverters, the film path ensures equal transfer of grouped products onto the film without skewing the product configuration. This is ideal for multipacks and irregular shaped products.

The machine controls are on a swing-arm that can be easily reached from either side of machine. Both right and left hand machines are available. A variety of standard "Quick-Connect" infeed conveyors are in stock to handle a wide range of products and are easily interchangeable.

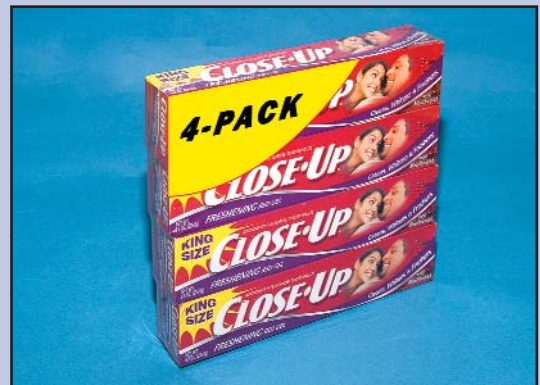



Operator controls can be reached from both sides of machine

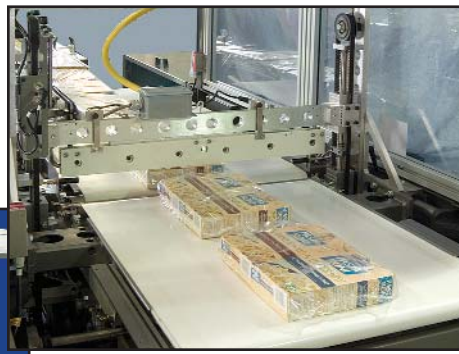

High speeds up to 140 feet per minute

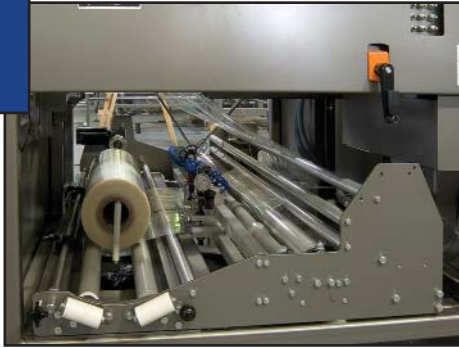

Low height slide out film rack for easy film loading

APPLICATIONS

- Plates
- Light bulbs
- Paper products
- Mailers
- Oil filters
- Boxes
- Cosmetics
- Pharmaceuticals
- Trays
- Games
- Software
- Multipacks
- Hardware
- CDs/DVD's



Patented film forming head for reliable transfer of products and fast easy film threading



Side sealer with "Easy Open" feature for fast cleaning and inspection

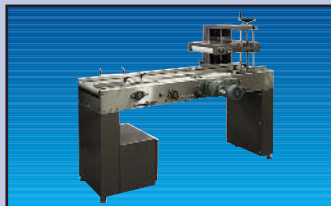

Variety of optional "Quick-Connect" conveyors



Gull wing doors provide unobstructed access

FEATURES

- Heavy-duty rugged construction designed for high durability and around-the-clock operation
- Servo driven seal carriage and seal head
- Tool-less change of flight pin spacing to accommodate products of different lengths
- 24" wide seal bar, with 10" seal opening
- Horizontal/vertical sealing capability
- Standard 6' flighted infeed conveyor
- Dial indicators on all manual adjustments
- Guards and control box doors are electrically interlocked
- Allen-Bradley® CompactLogix PLC
- Allen-Bradley® PanelView touchscreen interface, message display, package calculators and self-diagnostics
- Programmable recipes for a variety of product sizes
- Swivel mounted control panel provides access from both sides
- NEMA 12 electrical cabinet and controls
- Low film alert warns that a film changeover will soon be necessary
- Central point lubrication simplifies preventive maintenance
- Available with variety of "Quick-Connect" infeeds including:
 - lug infeeds in 6', 10', 15', 20' lengths
 - dual pacing belt infeed
 - flight bar infeeds in 10' and 20' lengths

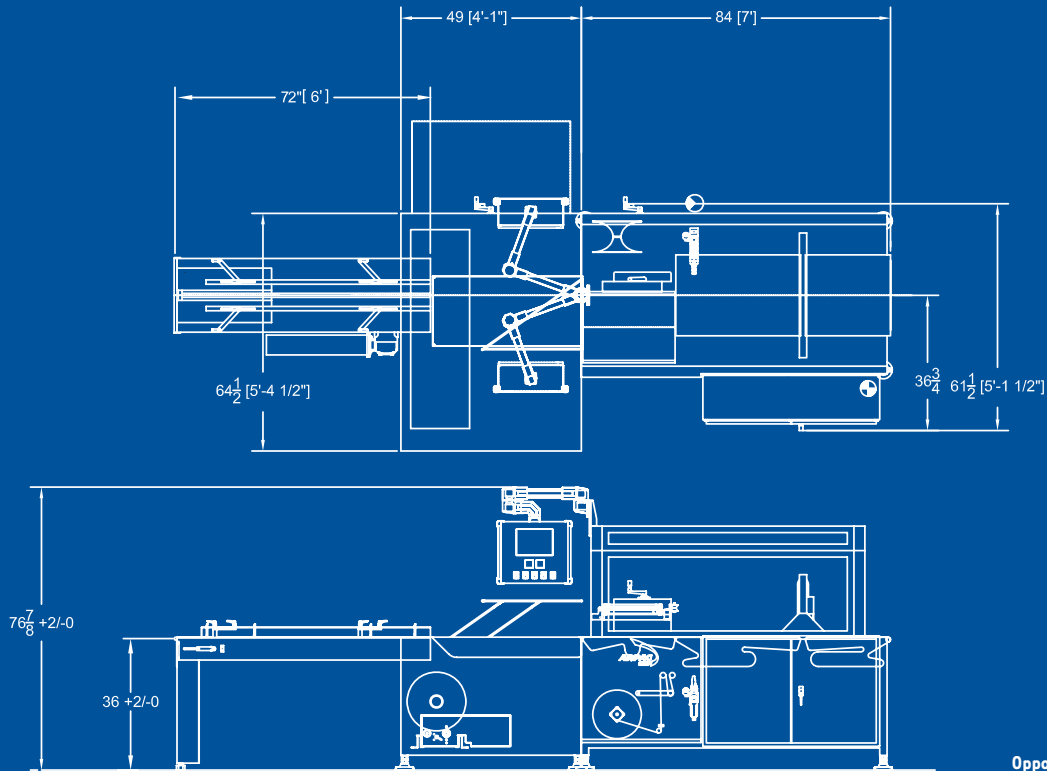

right hand model shown
Opposite hand available on request

SPECIFICATIONS

Speed

- Up to 140 packages per minute and 140 linear feet per minute

Power Requirements

- Electrical: 460VAC, 3Ph, 60Hz, 44A
Other voltages available on request
- Compressed air may be required for certain options

Product Range

- horizontal seal bar:
2" x 4" x .25" [min], 24" x infinite x 10" [max]*
- vertical seal bar:
2" x 10" x 2" [min], 10" x infinite x 12" [max]*

* Package maximums cannot occur together.

Film

- Max. film width: 50" single-wound
- Film type: polyolefin, polyethylene, PVC and PLA
- Clear or printed

OPTIONS

- Stainless-steel construction
- Band sealer for PVC and new generation high strength polyolefins
- Casters for machine portability
- Film cart
- UL / CSA approved electrical cabinet
- Stack light and horn
- Film print registration
- Low product detection
- Hole punch
- Shrink tunnel
- Customized infeeds



ARPAC L.P. 9511 West River Street | Schiller Park, IL 60176 USA | P 847 678 9034 | F 847 671 7006 | www.arpac.com

copyright ARPAC L.P. 2007

100407-00